

POWERDRILL DM202 NAIL DRILL MACHINE

Model: DM202

Certificate No.: AT0517090055S, AT0517090055E

TECHNICAL DATA:

Power: 65W

Input voltage: 220V AC

Output voltage: 12V-2A

Rotation speed: 35000 RPM

1. SAFETY OF USE:

1. Before use, read the operating instructions carefully.
2. Remember that the actual voltage used must correspond to the nail drill's parameters.
3. Do not use the device in a damp/wet area or when the air humidity level reaches high values.
4. If the nail drill machine is flooded, immediately disconnect it from the power source. A flooded device must not be used again. Return it to the manufacturer's service for inspection and possible repair.
5. Disconnect the power plug when the nail drill machine is not used for a long time.
6. Wipe with a mild detergent if the surface is dirty. Perform the operation with the equipment switched off (disconnect the power cable). Never clean with an acidic cleaning agent.
7. Rational use and proper maintenance can extend the life of the nail drill machine.
8. If the device does not work properly, ask a specialist to check the lower fuse for damage.
9. Keep out of reach of children.

2. THE SET INCLUDES:

- Nail drill machine
- Handpiece
- Drill bit set
- Foot drive
- User manual
- Holder for placing the handpiece
- Power cable
- Warranty card

3. CHARACTERISTICS OF THE DEVICE:

1. ON/OFF switch
2. Hand/foot switch
3. Left/right rotation switch
4. Head holder
5. Speed change knob
6. Head input socket
7. Foot drive input socket
8. Power cable
9. Space for drill bits
10. Operation indicator light

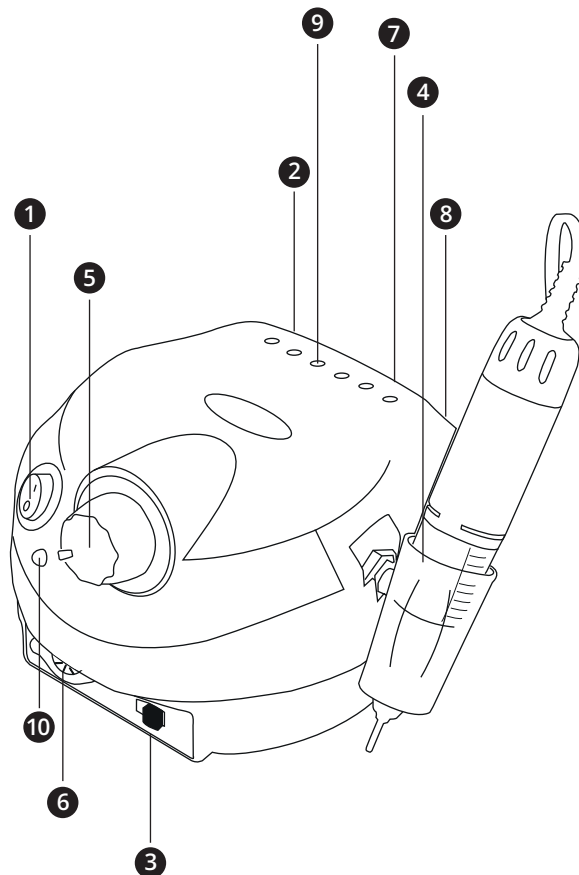

4. MAIN FUNCTIONS:

The nail drill machine was designed with professional manicure salons in mind, as well as users who do manicures at home. The user-friendly design and handpiece designed to give a sense of high comfort of work are the distinctive features of the device.

5. HOW TO USE:

1. Before connecting the nail drill machine to the power supply, make sure that the input voltage is the same as the voltage required by the device.
2. Connect the power cord to the outlet.
3. Connect the head of the nail drill machine to the appropriate input in the device, then connect the foot pedal to the pedal slot located on the back of the device.
4. Set the minimum speed of rotation.
5. Turn on the device - the indicator light will light up and the nail drilling head will start to rotate slowly.
6. Rotations of the nail drilling machine are adjusted by means of a knob.
7. After switching the button to "FOOT" use the foot pedal to turn on the nail drilling machine.
8. If the control lamp does not light up during the work of the nail drilling machine, you should check the fuse and replace it in case of failure.
9. If you do not use a nail drilling machine, remember to always turn off the power cable from the outlet.

6. DIRECTIONS:

1. Remember to connect the device to a socket with a voltage that is suitable for the device's requirements.
2. Keep the device out of reach of children.
3. Use a dry or slightly damp cloth with detergent to clean the device.
4. Use the device away from moisture. Avoid exposing the device to strong sunlight to prevent it from overheating.
5. Do not replace drill bits while the nail drill machine is running. This may cause irreversible damage to the handle.
6. If the device is not used for a long time, disconnect the power plug and store the device in a ventilated, dry place.



In accordance with *art. 13 sec. 1 of the Act of 11 September 2015 on used electrical and electronic equipment (Journal of Laws 2015 item 1688)*, we inform you about the correct handling of waste electrical and electronic equipment:

1. It is prohibited to place used electrical and electronic equipment together with other waste - this is confirmed by the marking in the form of a "crossed-out bin", which requires selective collection of this type of waste.
2. Electrical and electronic devices may contain hazardous substances, mixtures and components, which, after entering the environment, may pose a serious threat to the health and life of humans and living organisms.
3. Used electrical and electronic equipment should be transferred only to authorized collection points, the list of which should be included on the website of each Municipal Office.
4. Households play a key role in the waste management system for used electrical and electronic equipment due to the possibility of their direct transfer to authorized collection points and the elimination of undesirable social habits resulting in leaving waste equipment in places not intended for this purpose.

IMPORTER

Made in PRC